

3D VIEW

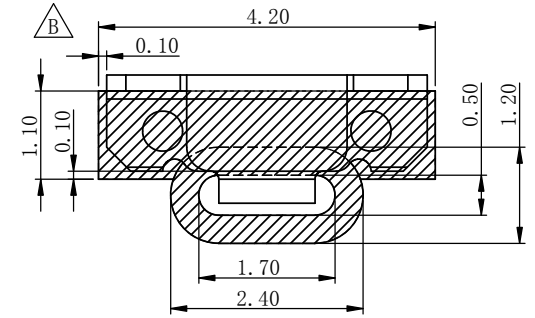

RECOMMENDED PCB LAYOUT

TOLERANCE  $\pm 0.05\text{mm}$  , PCB THICKNESS: 0.80mm

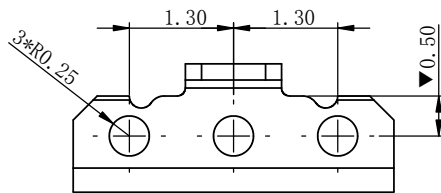
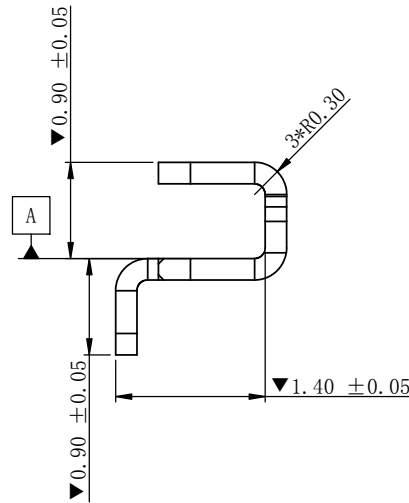
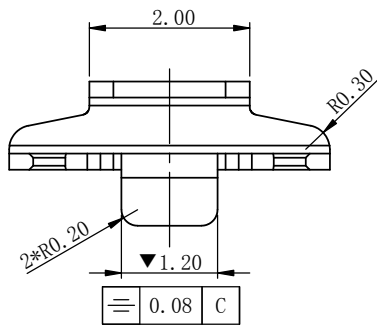

NOTES:

1. MATERIAL:  
1-1: C7521R-1/2H, T=0.20mm
2. FINISH:  
2-1: 50u"MIN BRIGHT TIN,  
50u"MIN NICKEL UNDERPLATING PVER ALL.
3. SPECIFICATIONS:  
3-1. RATING CURRENT: 1A MAX. PER CONTACT.  
3-2. RATING VOLTAGE: 12V.  
3-3. CONTACT RESISTANCE: 50mΩ MAX.
4. OPERATION TEMPERATURE: -25° C ~ +65° C.  
STORAGE TEMPERATURE: -40° C ~ +85° C.
5. PACKING SPECIFICATION: TAPE & REEL.
6. COMPLIANT WITH RoHS STANDARD.

				UNITS: mm	GENERAL TOLERANCE		DRAW:	PART NO: P78-AB01A110
				DATE: 01/18/2020	X. $\pm 0.20$	X' $\pm 2.00$	CHECKED:	NAME: 压紧钢片卡勾
B	E2005130A	依客户要求更新焊盘尺寸及电镀规格	05/08/2020	SCALE: 20 / 1	X $\pm 0.15$	X' $\pm 1.00$	APPROVE:	DRAWING NO: C-P78-0000-B
A		NEW	02/04/2020	SHEET: 1 / 1	.XX $\pm 0.10$	.XX' $\pm 0.50$		
REV.	ECN NO.	DESCRIPTION	DATE	REV. B	TITLE: CUSTOMER-DRAWING		FINISH: SEE NOTE	



昆山捷皇电子精密科技有限公司  
HONGRIDA ELECTRONIC TECHNOLOGY CO., LTD.

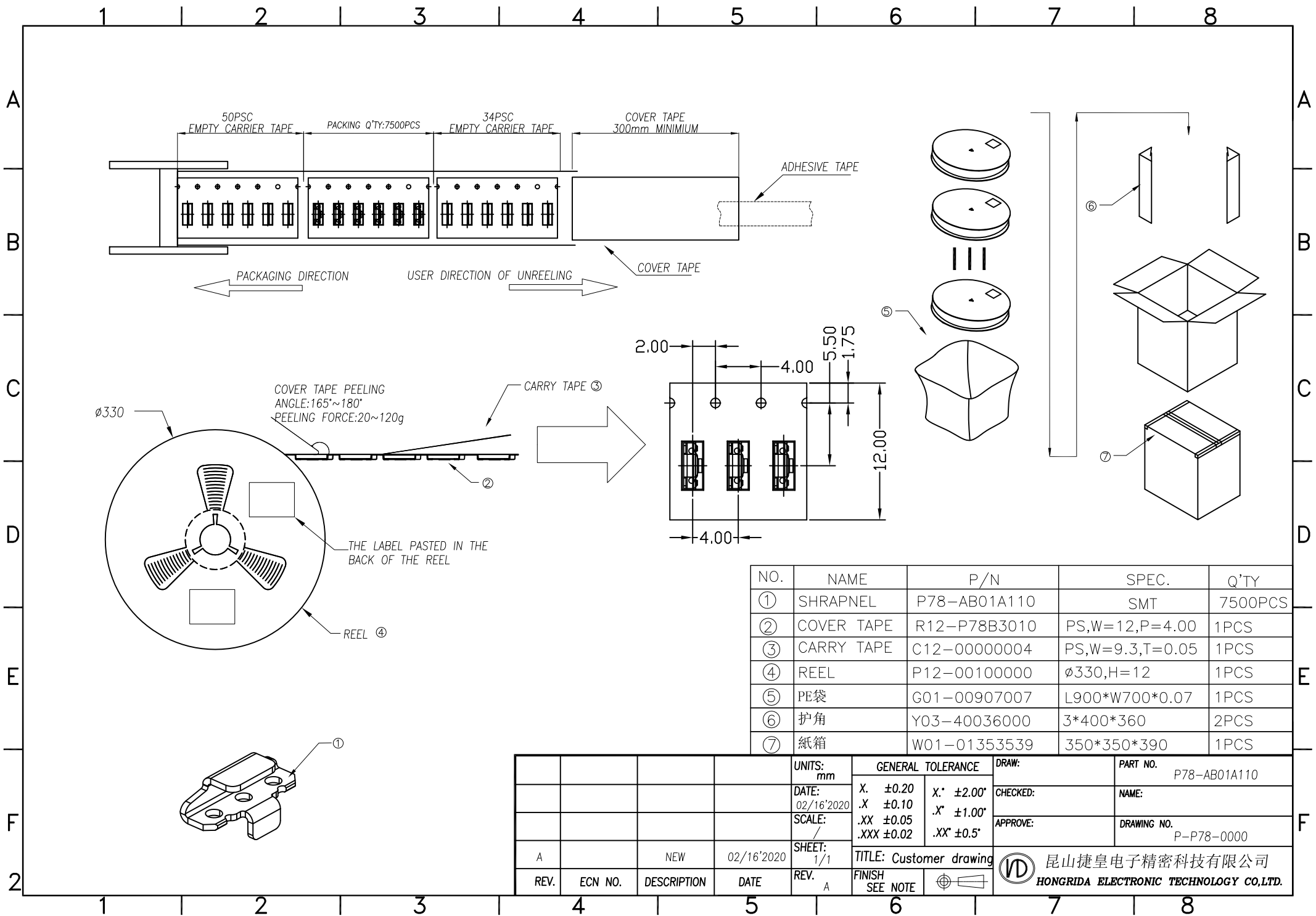

NO.	NAME	P/N	SPEC.	Q'TY
①	SHRAPNEL	P78-AB01A110	SMT	7500PCS
②	COVER TAPE	R12-P78B3010	PS,W=12,P=4.00	1PCS
③	CARRY TAPE	C12-00000004	PS,W=9.3,T=0.05	1PCS
④	REEL	P12-00100000	ø330,H=12	1PCS
⑤	PE袋	G01-00907007	L900*W700*0.07	1PCS
⑥	护角	Y03-40036000	3*400*360	2PCS
⑦	纸箱	W01-01353539	350*350*390	1PCS

				UNITS: mm	GENERAL TOLERANCE		DRAW:	PART NO. P78-AB01A110
				DATE: 02/16'2020	X. ±0.20	X' ±2.00'	CHECKED:	NAME:
				SCALE: /	.X ±0.10	.X' ±1.00'	APPROVE:	DRAWING NO. P-P78-0000
				SHEET: 1/1	.XX ±0.05	.XX' ±0.5'		
A		NEW	02/16'2020	REV. A	TITLE: Customer drawing		昆山捷皇电子精密科技有限公司 HONGRIDA ELECTRONIC TECHNOLOGY CO.,LTD.	
REV.	ECN NO.	DESCRIPTION	DATE	REV.	FINISH SEE NOTE			