

NO.	DESCRIPTION
1	GND / MIC+
2	MIC+ / GND
3	R AUDIO
4	L AUDIO / DETECT
5	DETECT / L AUDIO

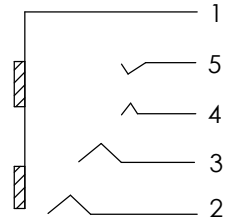
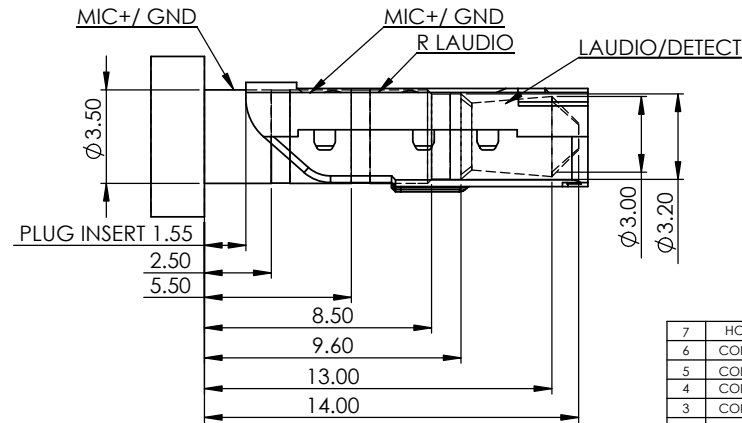
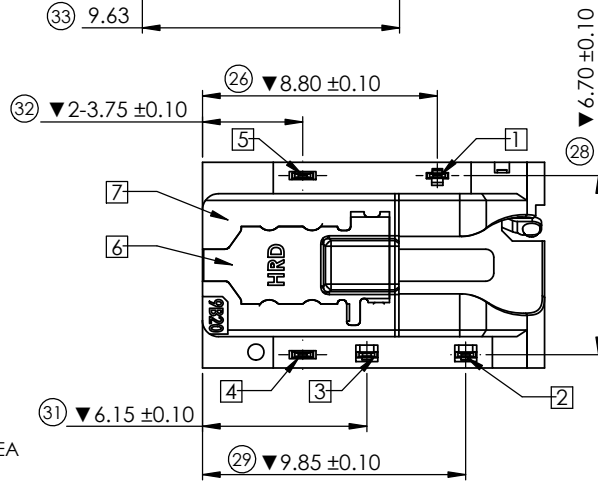
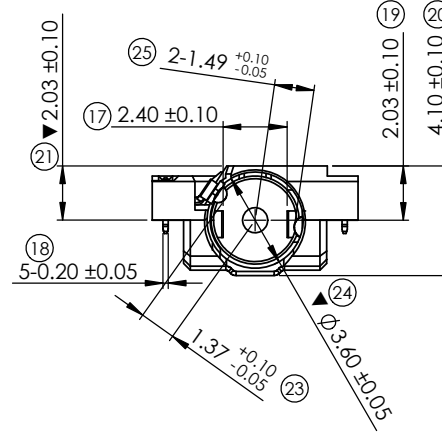
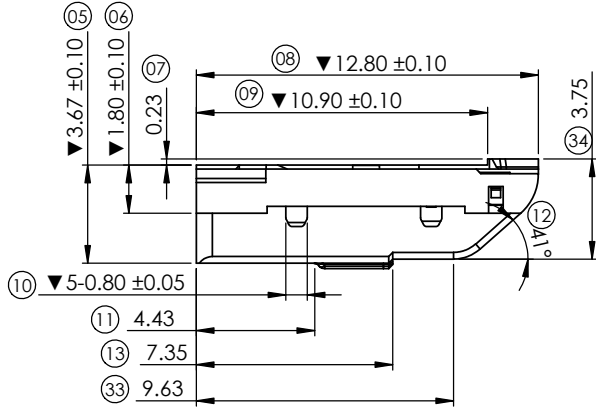
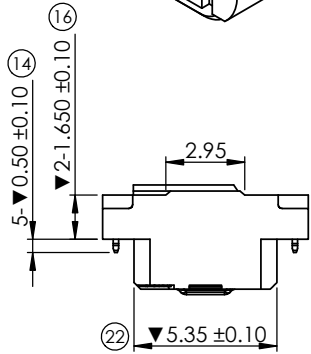
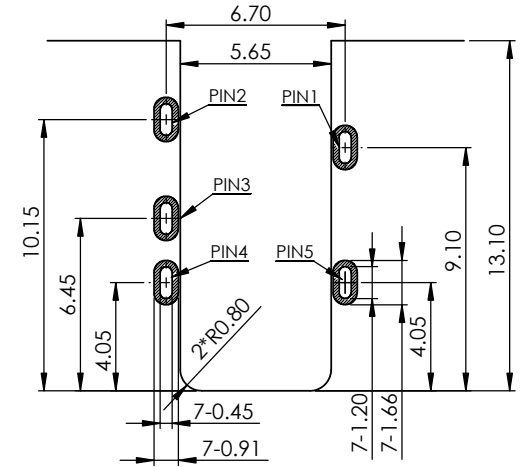

- NOTES:
1.MATERIAL:
HOUSING:PA 9T,BLACK,UL 94 V-0
CONTACT:SEE TABLE
2.FINISH:
15u" Min Au PLATING ON CONTACT AREA
1u" Min Au PLATING ON SOLDER AREA
50u" Ni UNDER PLATING OVER ALL
3.ALL DIMENSIONS MARKED ▼ MUST BE CONTROLLED BY QC
4.ALL DIMENSIONS MARKED (X) MUST BE MEASURE BY FAI
5.PRODUCT SPECIFICATIONS:
5-1 WITHSTANDING VOLTAGE: 500V AC/MINUTE
5-2 CONTACT RESISTANCE: 50 mΩ Max.
5-3 INSULATION RESISTANCE: 1000 MΩ Min.
5-4 BEFORE DURABILITY: MATING FORCE: 5-20 N.
UNMATING FORCE: 5-20 N.
5-5 AFTER DURABILITY:MATING FORCE: 4-20 N.
UNMATING FORCE:4-20 N.
5-6 OPERATION TEMPERATURE : -55° TO +85°
5-7 DURABILITY : 5000 CYCLES

NO.	Parts Name	Q'	TY	Material	Finish	Remarks
7	HOUSING	1		PA9T	UL94 V0	Black
6	CONTACT-6	1		SUS304-H		T=0.15
5	CONTACT-5	1		SUS304-3/4H	Ni+Au	T=0.20
4	CONTACT-4	1		SUS304-3/4H	Ni+Au	T=0.20
3	CONTACT-3	1		C5210-H	Ni+Au	T=0.20
2	CONTACT-2	1		C5210-H	Ni+Au	T=0.20
1	CONTACT-1	1		C5210-H	Ni+Au	T=0.20

REV.	ECN NO.	DESCRIPTION	DATE	REVISION	FINISH	SEE NOTE	UNIT: mm	GENERAL TOLERANCE	DRAW:	PART NO:
								X. ±0.25 .X' ±0.20 .XX ±0.15 .XXX ±0.08		PH92-9B20C41A
							DATE: 05/08/2018	X' ±2.00 .X' ±1.00 .XX ±0.50	CHECKED:	NAME: Ø3.50MM PHONE JACK CONN.
							SCALE: 5/1		APPROVE:	DRAWING NO: C-PH92-0900
							SHEET: 1/1			
							TITLE: Customer Drawing			



昆山捷皇电子精密科技有限公司
HONGRIDA ELECTRONIC TECHNOLOGY CO., LTD.

1 2 3 4 5 6 7 8

收料方向 GATHER MATERIAL DIRECTION
 客户放料方向 INPUT MATERIAL DIRECTION

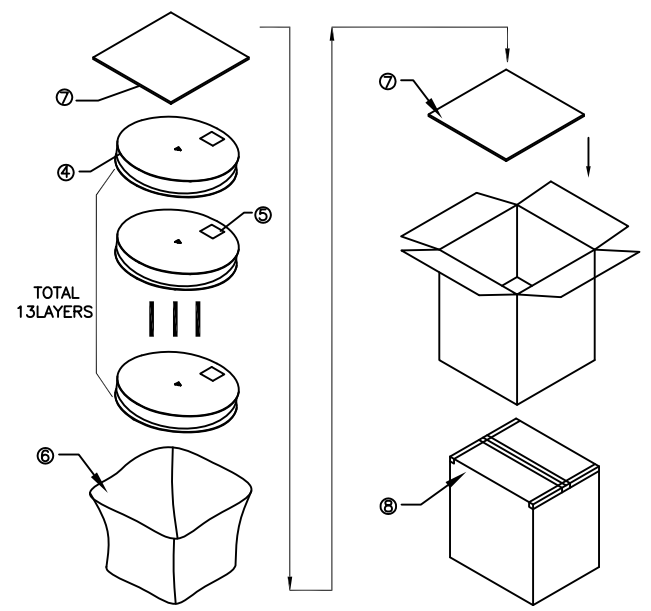
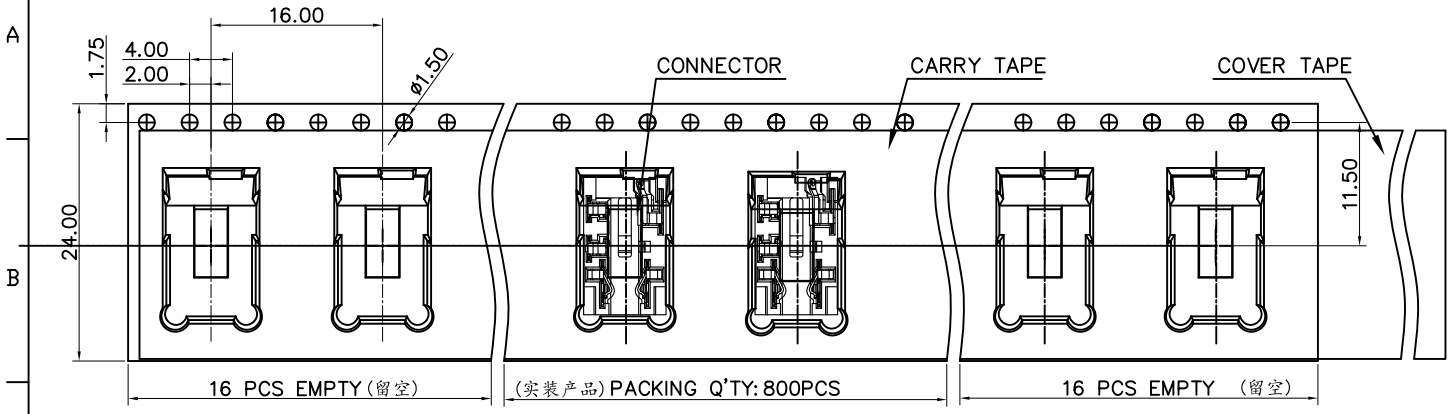

PH92-9B20C41A & 包装示意图

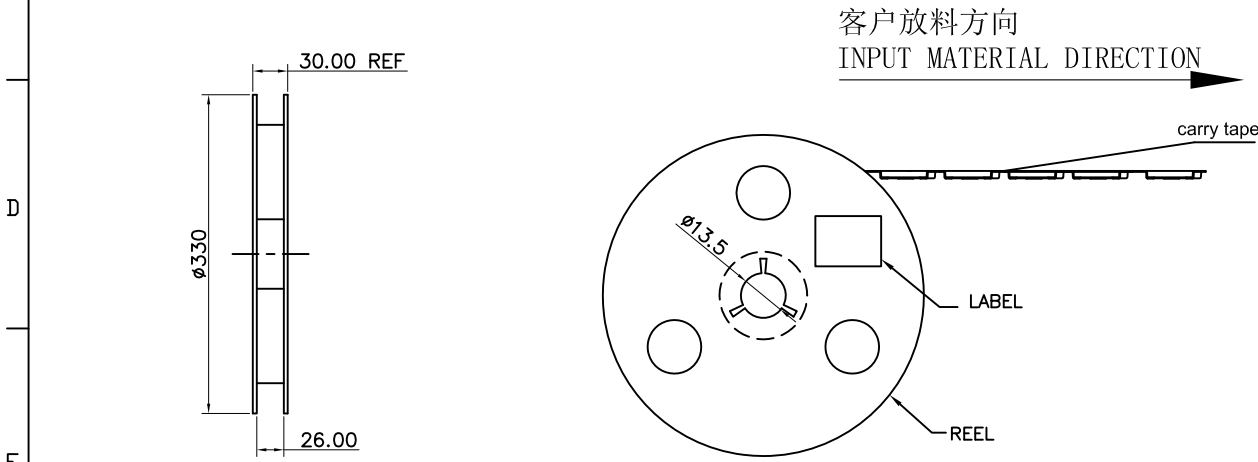

客户放料方向 INPUT MATERIAL DIRECTION

BOM:

NO.	NAME	P/N	SPEC.	Q'TY
①	PHONE JACK	PH92-9B20C41A	DIP	10400PCS
②	CARRY TAPE	R24-PH924800	PET,W=24.0,P=16.0	160.992m
③	COVER TAPE	C24-00100000	PE,W=21.3,T=0.05	160.992m
④	REEL	P24-01100000	$\phi 330,H=24.0$	13PCS
⑤	LABEL	L01-01000000		13PCS
⑥	PE袋	G01-00907007	900*700	1PCS
⑦	隔板	Y03-40036000	330*330*3	2PCS
⑧	纸箱	W01-01353539	350*350*390	1PCS

3				
2				
1	R24-PH924800	PET	WHITE	
NO.	DESCRIPTION	MAT,L	COLOR	REMARK

				UNITS: mm	GENERAL TOLERANCE	DRAW:	PART NO: PH92-9B20C41A
				DATE: 05/10'2018	X. ± 0.20 .X ± 0.15 .XX ± 0.10 .XXX ± 0.05	X. $\pm 2.00'$.X' $\pm 1.00'$.XX' $\pm 0.50'$	CHECKED:
				SCALE: N/A			APPROVE:
				A	NEW	05/10'2018	TITLE: $\phi 3.5\text{MM PHONE JACK CONN.}$
				REV. A	ECN NO.	DESCRIPTION	DRAWING NO:
							FINISH:
							SHIELD
							昆山捷皇电子精密科技有限公司 HRD ELECTRONIC TECHNOLOGY CO.,LTD.

1 2 3 4 5 6 7 8