

- NOTES:
- MATERIAL:
HOUSING: LCP, BLACK, UL 94V-0
CONTACT: PHOSPHOR BRONZE, T=0.12MM
SHELL: STAINLESS STEEL T=0.10MM
 - FINISH:
CONTACT: 50U' MIN PLATING OVER ALL
GOLD FLASH ON THE CONTACT AREA AND SOLDER AREA
SHELL: SELECTIVE GOLD FLASH ON SOLDER TAIL AREA
50U' NI MIN. PLATING OVER ALL
 - GP PASSED ACCORD WITH HRD-RoHS-219 STANDARD.
 - ALL DIMENSIONS MARKED ▼ MUST BE CONTROLLED BY QC
 - ALL DIMENSIONS MARKER (XX) MUST BE MEASURED BY FAI.

T-CARD PIN NO.	PIN NO.
T1	DAT2
T2	CD/DAT3
T3	CMD
T4	VDD
T5	CLK
T6	VSS
T7	DAT0
T8	DAT1

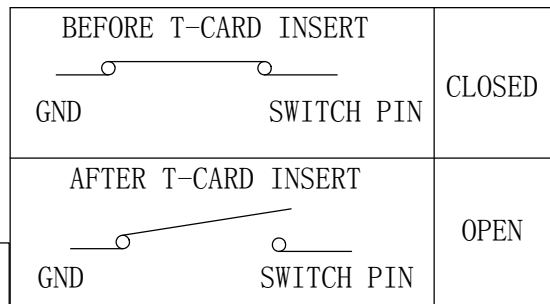

REV.	ECN NO.	DESCRIPTION	DATE
B	E1607275A	增加进胶点	08/02/2016
A		NEW	01/13/2016

UNITS:	GENERAL TOLERANCE	
mm	X. ±0.25	X° ±5.00°
DATE:	.X ±0.15	.X° ±3.00°
01/13/2016	.XX ±0.10	.XX° ±1.00°
SCALE:	.XXX ±0.05	.XXX° ±0.50°
10/1		
SHEET:	MATERIAL:	
1/1		
REV. A	FINISH:	
	SEE NOTE	

DRAW:	PART NO:
	T12-BB09F130
CHECKED:	TITLE:
	T-CARD 总高 1.35H 带检测PIN
APPROVE:	DRAWING NO:

 昆山捷皇电子精密科技有限公司
HONGRIDA ELECTRONIC TECHNOLOGY CO., LTD.